



MODEL:AC256P30/MI/8

10" Guitar 30w

Description

A direct-radiating, electro-dynamic, ferrite-magnet loudspeaker developed to replicate vintage 60's guitar models.

The cone is produced from selected softwood, hardwood and hemp fibers; this fiber formulation accurately reproduces each musical note with greater detail without blending. This tonal quality and reliability is achieved under our control, and is based on prior art and over 30 years of paper cone manufacturing experience.

This model employs a PESV voice-coil wound onto kraft paper bobbin to emulate the sixties sound, this prior art produces a low 30Watt-power rating. This model is the loudest and has the brightest high-frequency response of the "P" range of guitar loudspeakers.

The voice-coil is adhered to the cone body with a selected adhesive to ensure reliable performance but retain the sixties voicing characteristics.

The voice-coil, cone materials, and magnet properties have been selected to emulate the high efficiency, bright top end thus requiring moderate amplifier power for delivery.

This Australian hand crafted model is an excellent choice for serious musicians where high efficiency, classic 60's performance and high reliability are desired.

Application

Most suitable for use with vintage guitars and vintage low power guitar amplifiers. This model is highly recommended for quad cabinets. Quad cabinets reinforce the bass response by 6dB and therefore demand bright guitar loudspeakers; this model meets these requirements.

Open back cabinets are less complementary, this model produces a bright detailed sound therefore EQ is desirable in this application.

Options

Many variations to this basic model are available:

- Choice of impedance, resonance, dustcap, cone materials and treatments and bobbin materials available.
- Recone kits and repair service available.

Please discuss your requirements with us.

Mounting Details

Baffle opening diameter

front mounting 220 mm

rear mounting 220 mm

Mounting pattern:

four 5.6 x 11.3 mm slots equi-spaced on 238 mm PCD.

Flange thickness 8 mm

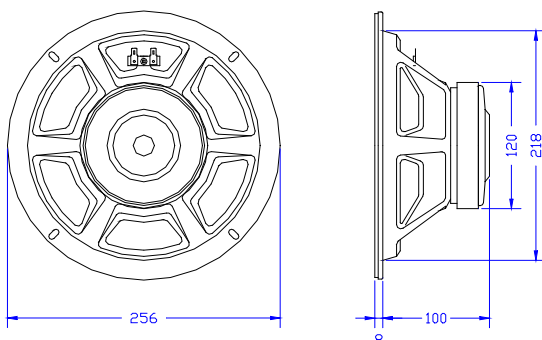

Technical Data

Typical measured Thiele/Small parameters:

Maximum program power	=	30 watt
Thermal power rating	=	30 watt rms
Rated nominal impedance	Z	= 8 ohms
Rated frequency range	=	50 - 7000 Hz
Piston sensitivity level	=	96.6 dB SPL
Max SPL @ 1w	=	102 dB SPL
Resonance frequency	=	85 Hz
Mechanical Q	Qm	= 14
Electrical Q	Qe	= 0.46
Total spk. Q	Qts	= 0.44
Moving mass	Mms	= 22 gms
Effective diaphragm diameter	D	= 20.0 cm
Effective diaphragm area	Sd	= .0316 sq.m.
Peak linear vol. displacement	Vd	= 63 cc
Vol. equiv to spk compliance	Vas	= 22.7 litres
Mechanical compliance	Cms	= 159 um/N
BL product	Bl	= 13 T.m
Voicecoil diameter	d	= 45 mm
Voicecoil material	=	Copper
Voicecoil DC resistance	Re	= 6.6 ohms
Voicecoil inductance @ 1kHz	Lvc	= 0.98 mH
Voicecoil height	=	10.0 mm
Height of air-gap	Hg	= 6 mm
Peak linear displacement	Xpk	= 2.0 mm
Reference efficiency	=	2.9 %
Speaker total mass	=	2300 gms

Specifications subject to change without notice.

Frequency Response

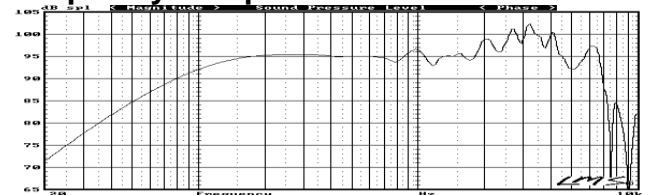

Typical LMS infinite baffle response recorded at one watt at one meter.

Impedance

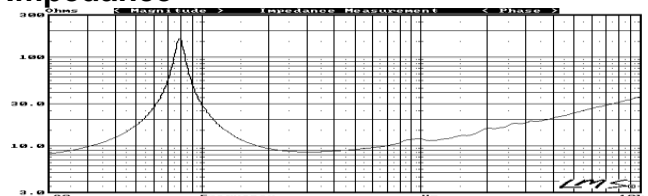

Typical measured impedance plot

Refer C264P/MI application notes for enclosure details.
Australian made loudspeaker