

Description

The AC213U-B4 is an Australian made professional 8" bass-mid loudspeaker with a useful upper limit of 4kHz. This model offers good bass performance, high power handling, high efficiency and large linear cone excursion.

Computer optimized design, leading Australian technology, and advanced materials produce superior performance.

The AC213U range features FEM optimized ferrite magnet assembly with vented t-yoke. The magnet components are engineered to achieve maximum efficiency.

This model features our curvilinear air dried OFP paper cone body with Kevlar reinforcing fibres and specially treated to produce smooth mids and wide frequency range. The cone body is terminated with a treated "M"-roll cloth-surround which ensures smooth mid band performance and provides the necessary cone excursion at high power. A selected paper dust-cap controls the upper frequency response.

The driver parameters have been carefully selected to produce full rich -bass in either a small vented or band-pass enclosure.

Reliable performance and 200W AES rating is achieved with a 50mm voice coil and state of art high temperature adhesives.

The AC213U model is engineered and hand crafted to the highest and strictest tolerances to meet the demanding requirements of professional sound monitoring applications.

Application

Professional high-quality monitor for live music, music play back systems and sound reinforcement applications in the frequency range 50 Hz to 4kHz where high power handling high spl and high quality are required. In the correct enclosure and under controlled conditions we recommend each AC213U-B4 be driven by a power amplifier capable of delivering 50 to 400 watts into 8 ohms. The bass signal must be processed to avoid excessive excursion beyond the rated safe rating.

Refer: -C213U-B4 application notes for enclosure details.

Model	Impedance
AC213U-B4-4	4 ohm
AC213U-B4-8	8 ohm
AC213U-B4-16	16 ohm

This datasheet applies to our AC213U-B4-8 model.

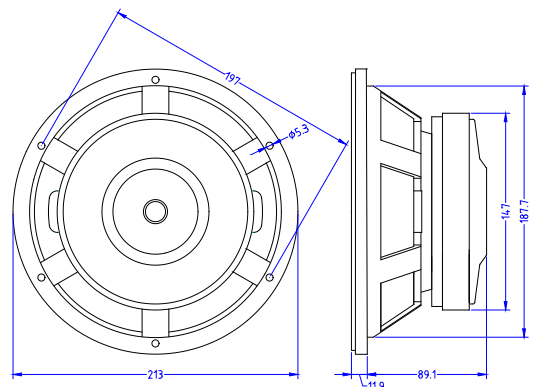

Mounting Details

- Baffle opening diameter front mounting 188 mm
- Mounting pattern: Four 6 x 5.3mm holes equi-spaced on a 197 mm PCD.
- Flange thickness 12 mm

Technical Data

Typical measured Thiele/Small parameters:

Maximum program power		400 W
AES Power Rating		200 W
#Rated nominal impedance		8 ohms
Rated frequency range		50 – 4000 Hz
Reference sensitivity level		94.5 dB SPL
Resonance frequency		60 Hz
Mechanical Q	Qm	4.9
Electrical Q	Qe	0.22
Total spk. Q	Qts	0.215
Diaphragm mass	Mmd	22.6 gms
Effective diaphragm diameter		17.0 cm
Effective diaphragm area	Sd	227 sq.cm.
Compliance	Vas	21.0 litres
BL product	Bl	16.0 T.m
Voicecoil diameter	d	50 mm
Voicecoil material		copper
Voicecoil DC resistance	Re	6.1ohms
Voicecoil inductance	Lvc	1.3 mH
Voicecoil height	Hvc	16 mm
Height of air-gap	Hg	8mm
Peak linear displacement	Xpk	5.0 mm
X damage (peak to peak)	Xp-p	25mm
Reference efficiency		1.95 %
Speaker total mass		3800 gms

*Specifications subject to change without notice.
Also available in 4 or 16 ohm impedance.*

Notes

- (1) AES power determined according to AES2-1984 standard in free-air. Power calculated on minimum impedance.
- (2) Maximum recommended program power is twice AES power providing the safe excursion limits are not exceeded.
- (3) Reference sensitivity is SPL at 1W at 1m derived from Thiele/Small parameters.
- (4) Frequency range is the useful frequency range for this transducer when mounted in its recommended enclosure.
- (5) Thiele/Small parameters are derived after the speaker has been preconditioned and is a better representation of the drivers long term parameters in use.
- (6) Peak linear displacement Xpk derived from Klippel XBL measurement.

Frequency Response

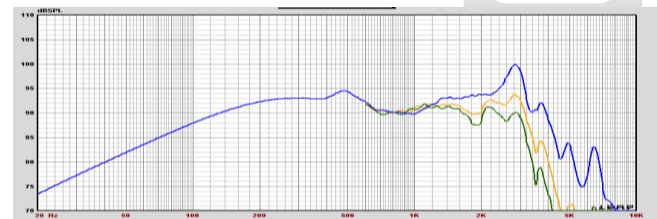

Infinite baffle sound pressure response recorded at one watt at one meter.

- Blue curve is on axis spl response
- Orange curve is SPL response at 30 degrees off axis.
- Green curve is SPL response at 40 degrees off axis.

Impedance plot

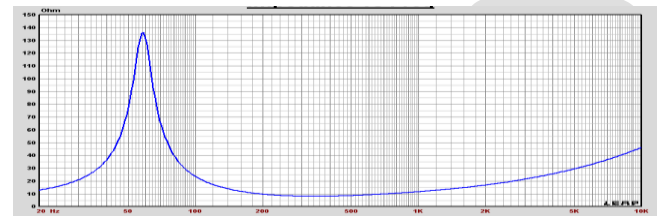

Free-air impedance magnitude plot.

